

## 600V-15A 3-Phase IGBT Inverter Bridge Including

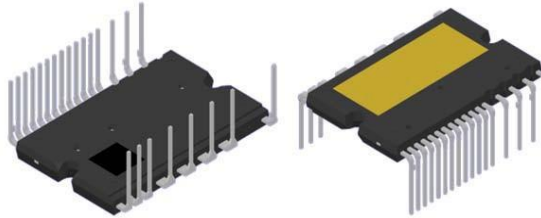

### MAIN FUNCTION AND RATINGS

- ◎ 3 phase DC/AC inverter
- ◎ Open emitter for all phase
- ◎ Temperature monitor
- ◎ Over current shutdown
- ◎ N-side IGBT open emitter
- ◎ Integrated bootstrap functionality
- ◎ Under-voltage lockout at all channels
- ◎ All of 6 switches turn off during protection
- ◎ 600V / 15A Low Vce(sat) Field-Stop IGBTs

### Target Applications

- ◎ Home appliances
- ◎ Low power motor drives

### Internal Electrical Schematic

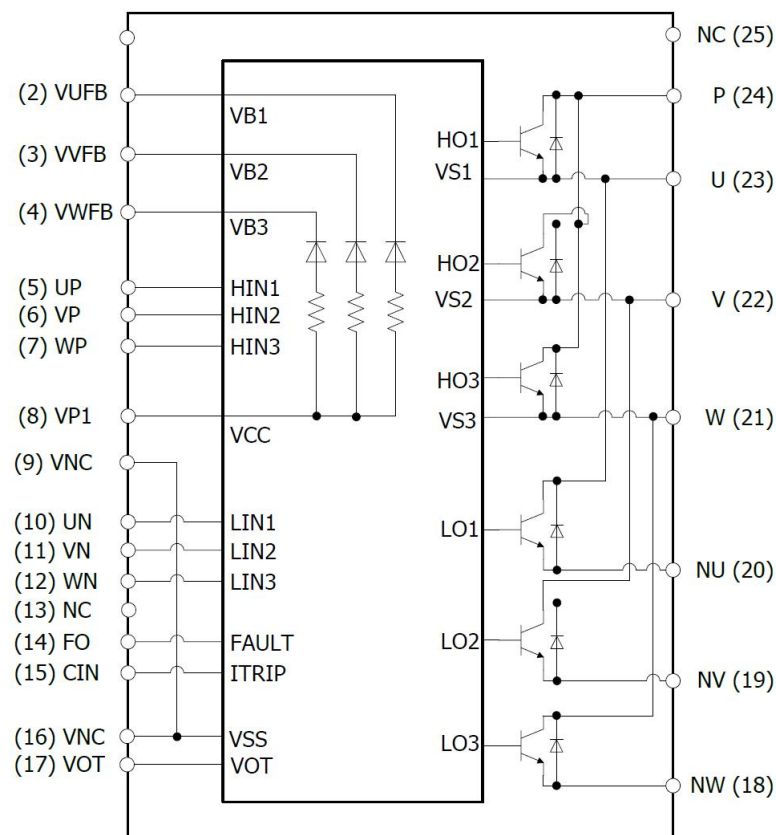

Pin Assignment

Pin Number	Pin Name	Pin Description
1	NC	No Connection
2	VUFB	U-phase high side floating IC supply voltage
3	VVFB	V-phase high side floating IC supply voltage
4	VWFB	W-phase high side floating IC supply voltage
5	UP	U-phase high side gate driver input
6	VP	V-phase high side gate driver input
7	WP	W-phase high side gate driver input
8	VP1	Low side control supply
9	VNC	Low side control negative supply
10	UN	U-phase low side gate driver input
11	VN	V-phase low side gate driver input
12	WN	W-phase low side gate driver input
13	NC	No Connection
14	FO	Fault output
15	CIN	Analog input for over-current shutdown
16	VNC	Low side control negative supply
17	VOT	Temperature monitor
18	NW	W-phase low side emitter
19	NV	V-phase low side emitter
20	NU	U-phase low side emitter
21	W	Motor W-phase output
22	V	Motor V-phase output
23	U	Motor U-phase output
24	P	Positive bus input voltage
25	NC	No Connection



### CONTROL (PROTECTION) PART

Symbol	Description	Condition	Ratings	Unit
VD	Control supply voltage	Applied between VP1-VNC, VN1-VNC	17.5	V
VDB	Control supply voltage	Applied between VUFB-U, VVFB-V, VWFB-W	17.5	V
VIN	Input voltage	Applied between UP, VP, WP-VPC, UN, VN, WN-VNC	-1~+10	V
VFO	Fault output supply voltage	Applied between FO-VNC	-0.5~ VD+0.5	V
IFO	Fault output current	Sink current at FO terminal	1.5	mA
VSC	Current sensing input voltage	Applied between CIN-VNC	-0.5~ VD+0.5	V

### TOTAL SYSTEM

Symbol	Description	Condition	Ratings	Unit
VCC (PROT)	Self protection supply voltage limit(SC)	VD = VDB= 13.5~16.5V Tj = 150°C, non-repetitive, less than 2μs	400	V
Tc	Module case operation emperature	Measurement point of Tc is provided in Fig.1	-20~+100	°C
Tstg	Storage temperature		-40~+125	°C
Viso	Isolation voltage	60Hz, Sinusoidal, AC 1min, between connected all pins and heat sink plate	2500	Vrms

### THERMAL RESISTANCE

Symbol	Description	Condition	Min.	Typ.	Max.	Unit
Rth(j-c)Q	Junction to case thermal resistance	Inverter IGBT part (per 1/6 module)	-	-	3.2	°C/W
Rth(j-c)F		Inverter FW Di part (per 1/6 module)	-	-	4	°C/W

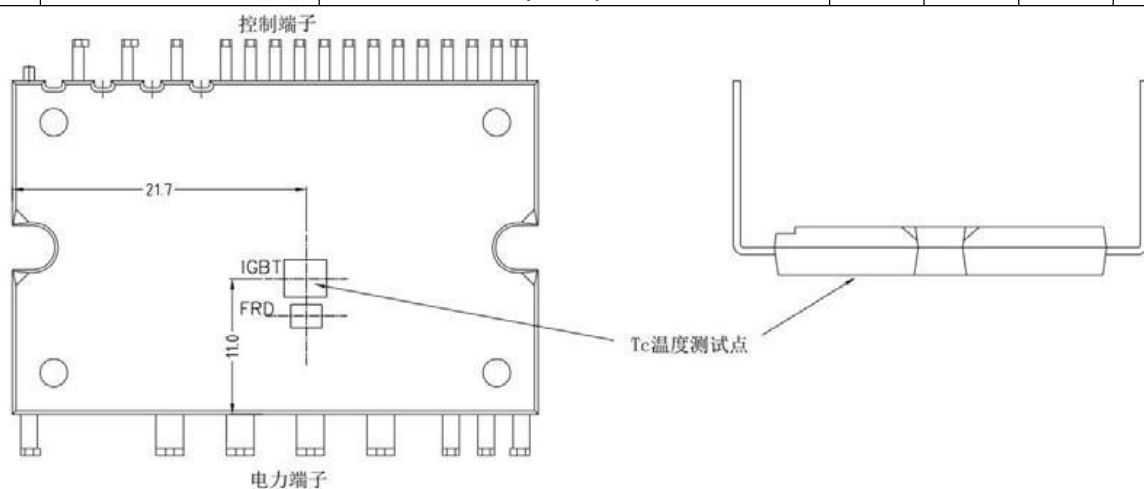

Fig.1 Tc MEASUREMENT POINT

ELECTRICAL CHARACTERISTICS ( $T_j = 25^\circ\text{C}$ , unless otherwise noted)

INVERTER PART

Symbol	Description	Condition	Min.	Typ.	Max.	Unit
VCE(sat)	Collector-emitter saturation voltage	VD = VDB = 15V VIN = 5V, IC = 15A, Tj = 25°C	-	1.8	2.0	V
		VD = VDB = 15V VIN = 5V, IC = 15A, Tj = 125°C	-	2.1	-	V
VF	Diode forward voltage	VIN = 0V, IC = -15A, Tj = 25°C		1.5	1.7	V
tON	Turn-on propagation delay time	IC = 15A, VCC = 300V, VD=VDB = 15V, RG = 22Ω, L = 500uH, Tj = 25°C	-	675	-	ns
tr	Turn-on rise time		-	25	-	ns
tC(ON)	Turn-on switching time		-	70	-	ns
tOFF	Turn-off propagation delay time		-	950	-	ns
tf	Turn-off fall time		-	90	-	ns
tC(OFF)	Turn-off switching time		-	120	-	ns
trr	Reverse recovery time		-	140	-	ns
Eon	turn-on energy		-	240	-	uJ
Eoff	turn-off energy		-	400	-	uJ
ICES	Collector-Emitter leakage current		VCE= VCES Tj= 25°C	-	-	75
		VCE= VCES Tj= 125°C	-	-	1	mA

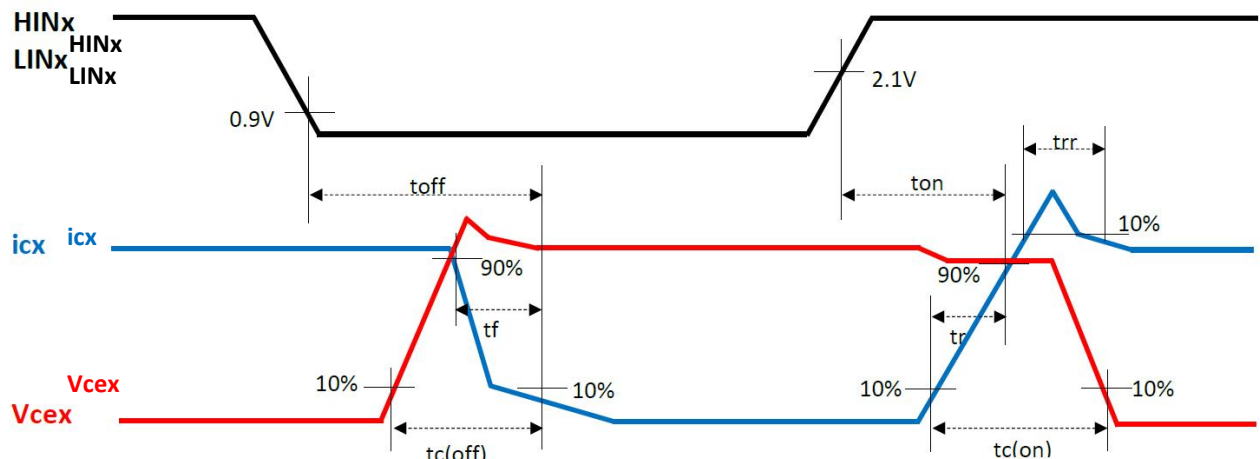

Fig.2 Switching times definition

**CONTROL (PROTECTION) PART**

Symbol	Description	Condition		Min.	Typ.	Max.	Unit
ID	VD Circuit current	VD = 15V	VP1-VNC	-	0.52	1	mA
		VIN = 5V					
IDB	VDB Circuit current	VDB = 15V	UFB-U, VFB-V, WFB-W	-	360	550	uA
		VIN = 5V					
VFOH	Fault output voltage	Vsc = 0V, Should be pulled up to 5V with 10K resistor		4.6	-	-	V
VFOL		Vsc = 1V, IFO=1.5mA		-	-	0.3	V
Vsc,TH+	Positive going threshold	VD = 15V		0.37	0.47	0.65	V
Vsc,TH-	Negative going threshold	VD = 15V		0.2	0.4	-	V
UVDD	supply under-voltage lockout	Positive going threshold		11	12.1	12.8	V
UVDR		Negative going threshold		9.5	10.4	11	
UVDBD		Positive going threshold		11	12.1	12.8	
UVDBR		Negative going threshold		9.5	10.4	11	
Ron,FLT	FAULT low on resistance of the pull down transistors	I=1.5mA			50	90	ohm
TFO	Fault output pulse width			40	65	120	uS
tFIL,IN	Input filter time(UP/VP/WP, UN/VN/WN)	VIN = 0 V & 5 V		140	290	-	nS
tCINMIN	CIN Input filter time	VIN = 0 V or 5 V, VCIN = 5 V		270	530	780	nS
VIN(ON)	Logic "1" input voltage	UP,VP,WPN		1.7	2.1	2.4	V
VIN(OFF)	Logic "0" input voltage	UN,VN,WN		0.7	0.85	1.4	
VOT	Temperature Output (Note3)	Tc=90°C		2.63	2.77	2.91	V
		Tc=25°C		0.88	1.13	1.39	
VF	Bootstrap Di forward voltage	IF=10mA		-	1	1.3	V
RBSD	Built-in limiting resistance	VF1=4V, VF2=5V		22	36	50	ohm

Note3: IPM don't shutdown IGBTs and output fault signal automatically when temperature rises excessively. When temperature exceeds the protective level that user defined, controller (MCU) should stop the IPM. Temperature of LVIC vs. VOT output characteristics is described by Fig.3.

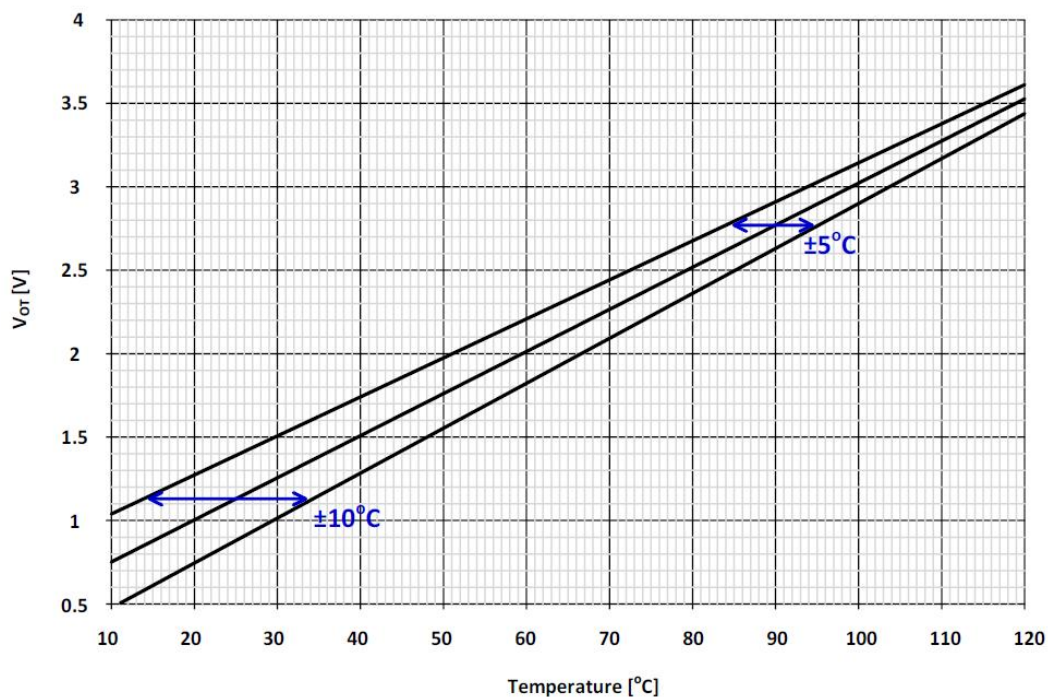

Fig.3 Temperature Profile of VOT(Typical)

## RECOMMENDED OPERATION CONDITIONS

Symbol	Description	Condition	Min.	Typ.	Max.	Unit
VCC	Supply voltage	Applied between P-NU, NV, NW	0	300	400	V
VD	Control supply voltage	Applied between VP1-VNC	-	15	-	V
VDB	Control supply voltage	Applied between VUFB-U, VVFB-V, VWFB-W	-	15	-	V
t <sub>dead</sub>	Dead time	For each input signal	1	-	-	μs
f <sub>PWM</sub>	PWM input frequency	-20 ≤ TC ≤ 100°C, -20 ≤ Tj ≤ 125°C	-	-	20	kHz
PWM IN	MiN. input pulse width	ON	0.7	-	-	
		OFF	0.7	-	-	μs
Tj	Junction temperature		-20	-	125	°C

## MECHANICAL CHARACTERISTICS AND RATINGS

Parameter	Condition	Min.	Typ.	Max.	Unit
Mounting torque	Mounting screw : M3	0.59	0.69	0.78	N·m
Design flatness		-50	-	120	μm
Weight		-	7	-	g

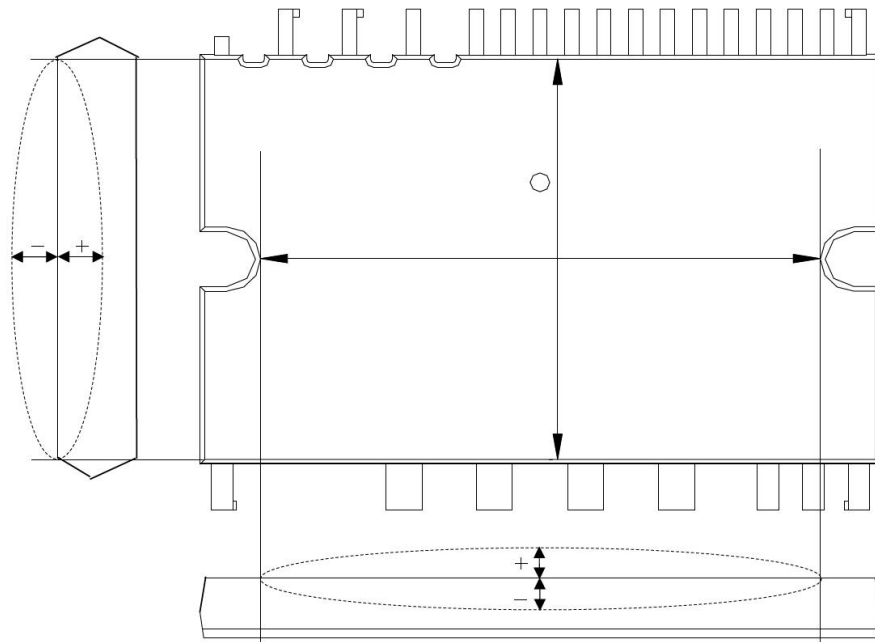
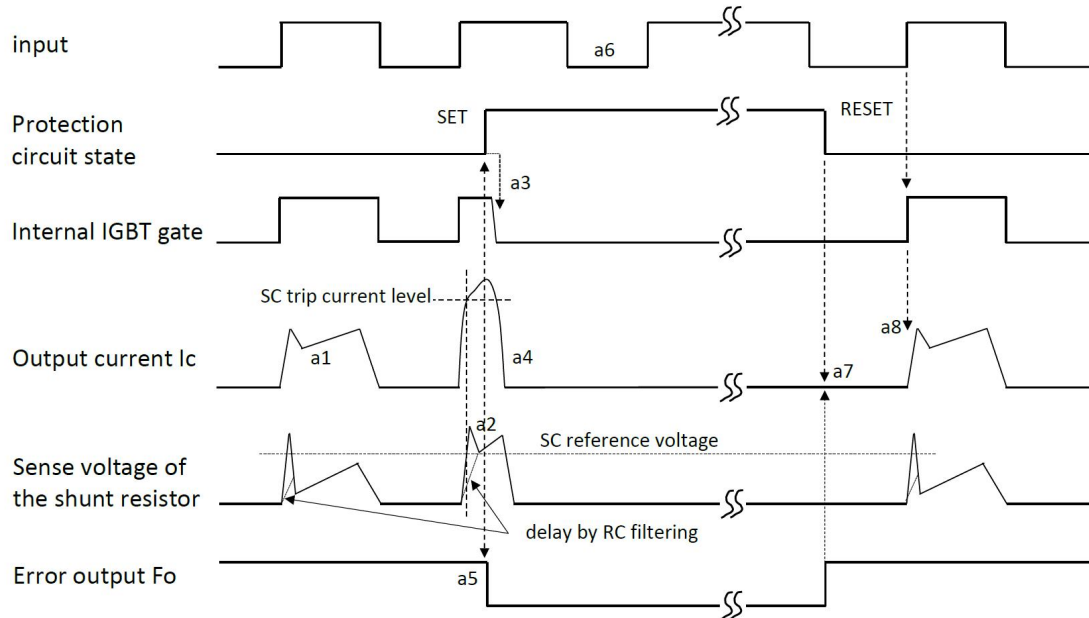

Fig.4 Measurement point of heat sink flatness



## Timing Charts of The IPM Protective Functions

### Short-Circuit Protection (N-side only )



a1. Normal operation: IGBT ON and outputs current.

a2. Short circuit current detection (Cin trigger)(It is recommended to set RC time constant 1.5~2.0 $\mu$ s so that IGBT shut down within 2.0 $\mu$ s when SC.)

a3. All N-side IGBT's gates are hard interrupted.

a4. All N-side IGBTs turn OFF.

a5. FO outputs for tFo( The pulse width is set by the external capacitance CFO).

a6. Input = "L" : IGBT OFF

a7. Fo finishes output, but IGBTs don't turn on until inputting next ON signal (L→H).(IGBT of each phase can return to normal state by inputting ON signal to each phase.)

a8. Normal operation: IGBT ON and outputs current.

### Under-Voltage Protection (N-side, UVD)

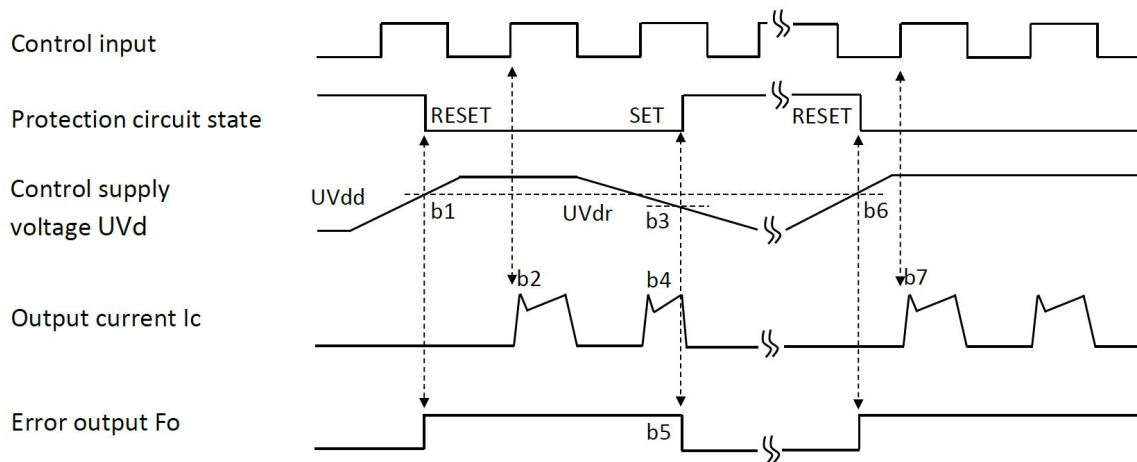

b1. Control supply voltage VD exceeds under voltage reset level (UVDr), but IGBT turns ON by next ON signal (L→H). (IGBT of each phase can return to normal state by inputting ON signal to each phase.)

b2. Normal operation: IGBT ON and outputs current.

b3. VD level drops to under voltage trip level. (UVdt).

b4. All N-side IGBTs turn OFF in spite of control input condition.

b5. Fo output

b6. VD level reaches UVDr.

b7. Normal operation: IGBT ON and outputs current.

### Under-Voltage Protection (P-side, UVDB)

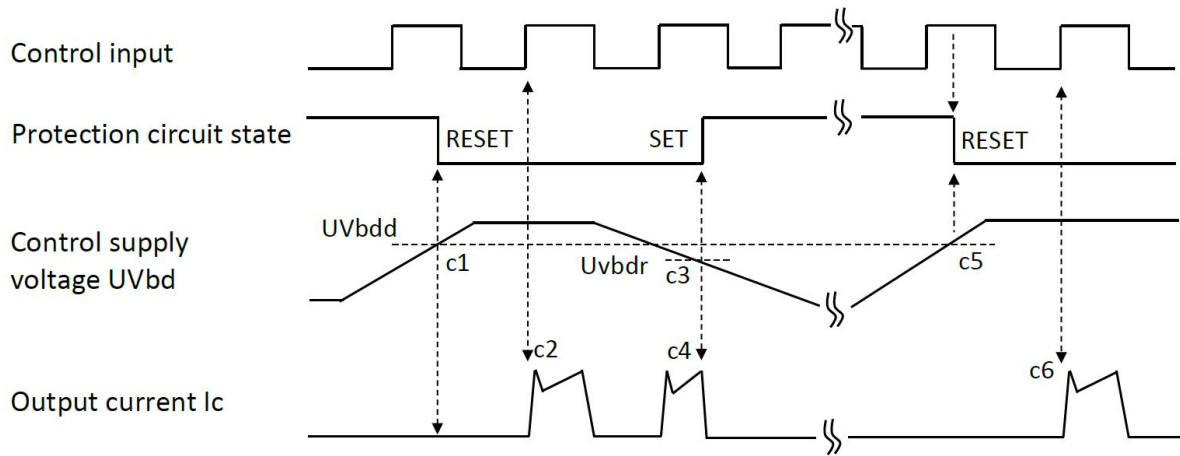

c1. Control supply voltage VDB rises. After the voltage reaches under voltage reset level  $UV_{Dbr}$ , IGBT turns on by next ON signal (L-->H).

c2. Normal operation: IGBT ON and outputs current. c3.

VDB level drops to under voltage trip level ( $UV_{DBt}$ ).

c4. IGBT of the correspond phase only turns OFF in spite of control input signal level.

c5. VDB level reaches  $UV_{DBr}$ .

c6. Normal operation: IGBT ON and outputs current.

Circuit of a Typical Application

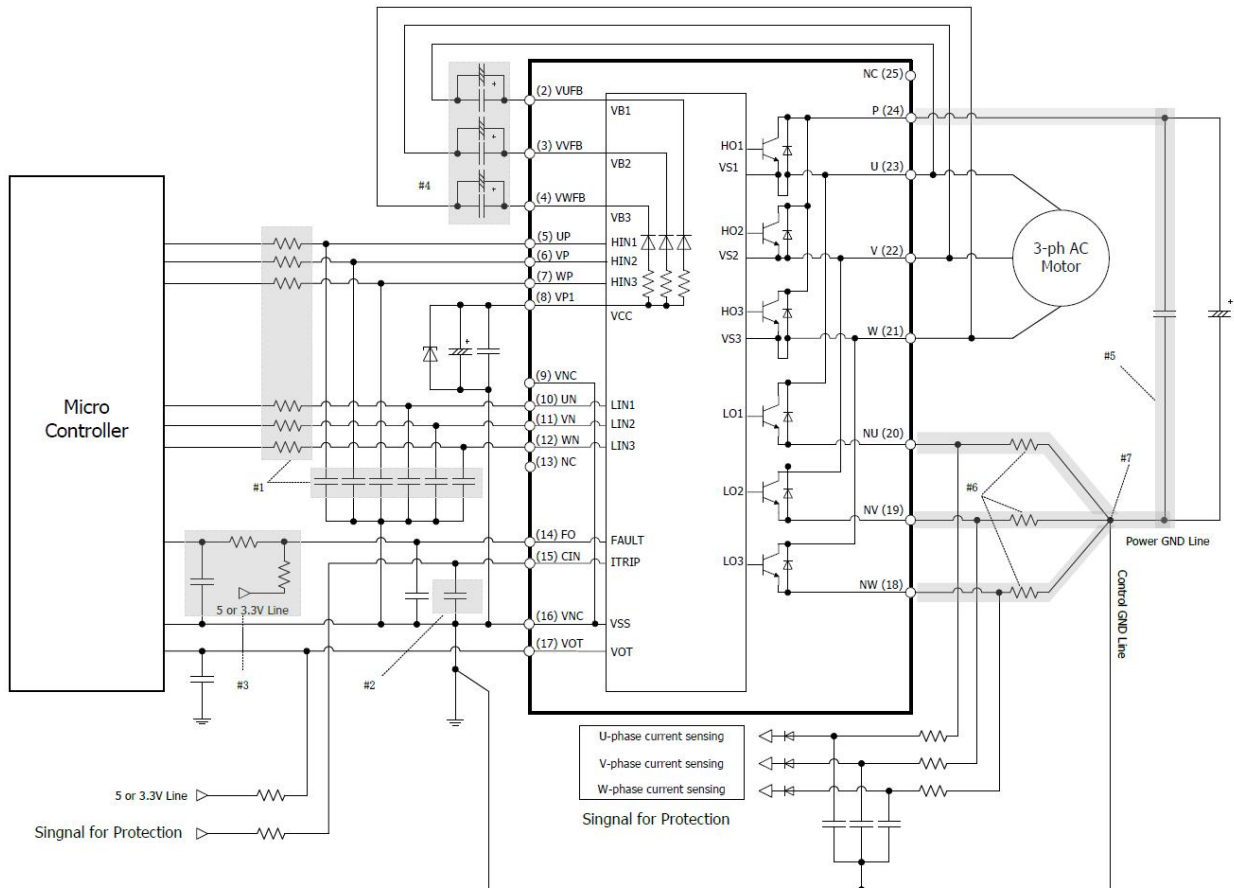

1. Input circuit

To reduce input signal noise by high speed switching, the RIN and CIN filter circuit should be mounted. (100Ω, 1nF),CIN should be placed as close to VNC pin as possible.

2. Itrip circuit

To prevent protection function errors, CITRIP should be placed as close to CIN and VNC pins as possible.

3. VFO circuit

VFO output is an open drain output. This signal line should be pulled up to the positive side of the 5V/3.3V logic power supply with a proper resistor RPU.It is recommended that RC filter be placed as close to the controller as possible.

4. VFB-VS circuit

Capacitor for high side floating supply voltage should be placed as close to VFB and U V W pins as possible.

5. Snubber capacitor

The wiring between IPM and snubber capacitor including shunt resistor should be as short as possible.

6. Shunt resistor

The shunt resistor of SMD type should be used for reducing its stray inductance.

7. Ground pattern

Ground pattern should be separated at only one point of shunt resistor as short as possible.

## Package Outlines

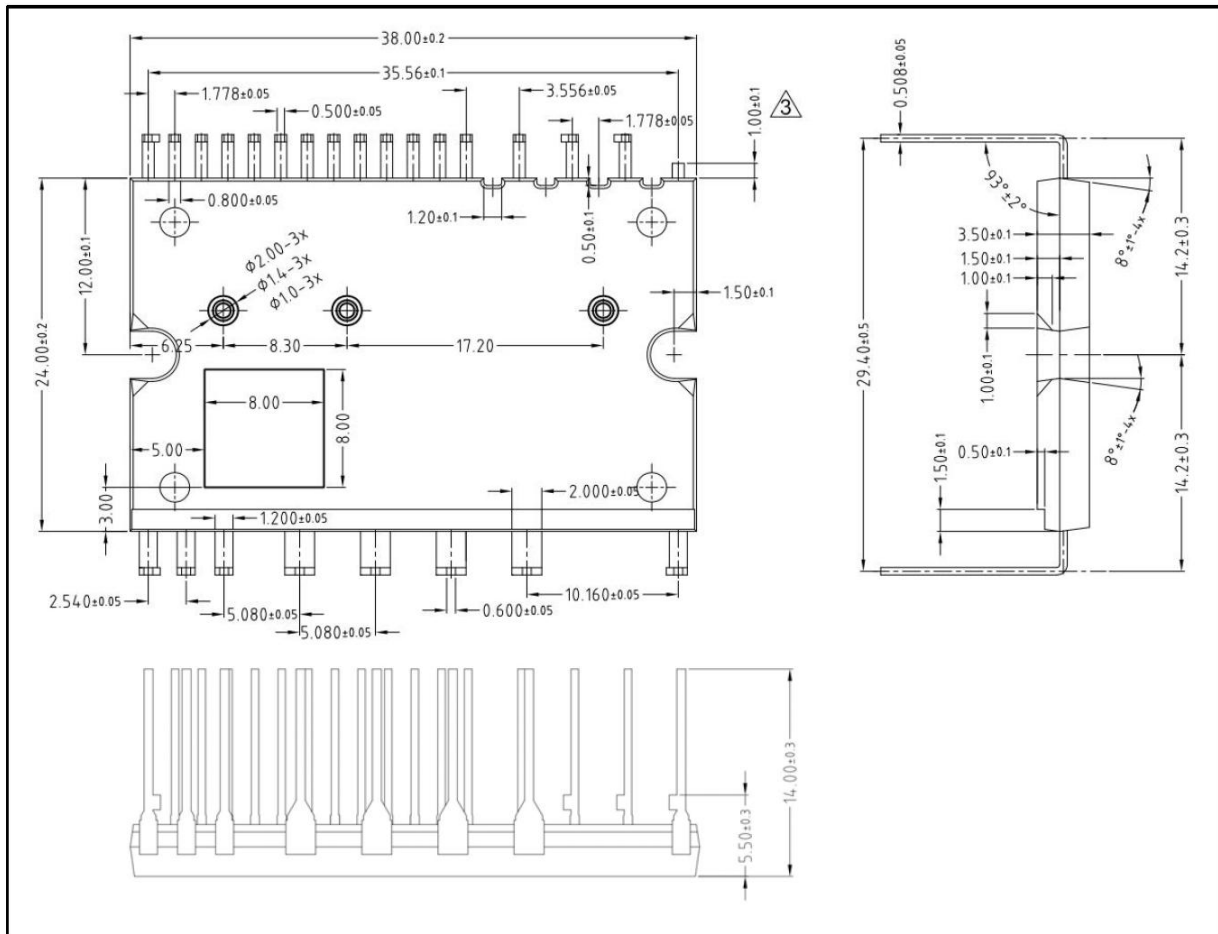

## Revision Record

Rev.	Date	Revised contents
01	Apr./2021	New
02	Oct./2022	VOT Parameter update